

12 Yard Decumulative Aggregate Scale Hopper



Scale Hopper

- Two Compartment 12 Yard Scale Hopper
- Weigh System with Digital Indicator and Decumulative Batching Software
- Structural Support Stand
- 24" x 38'-6" Long Belt Conveyor
- Gear Box Drive with Back Stop and Motor
- (2) Discharge Gates with Cylinders and Limit Switches
- (2) Air Vibrators with Air Hose
- Collecting Hopper with Gum Rubber Boot
- Torsion Style Belt Wiper
- Water Pipe
- Optional: Upgrade to 30" Belt

12 Yard Decumulative Aggregate Scale Hopper

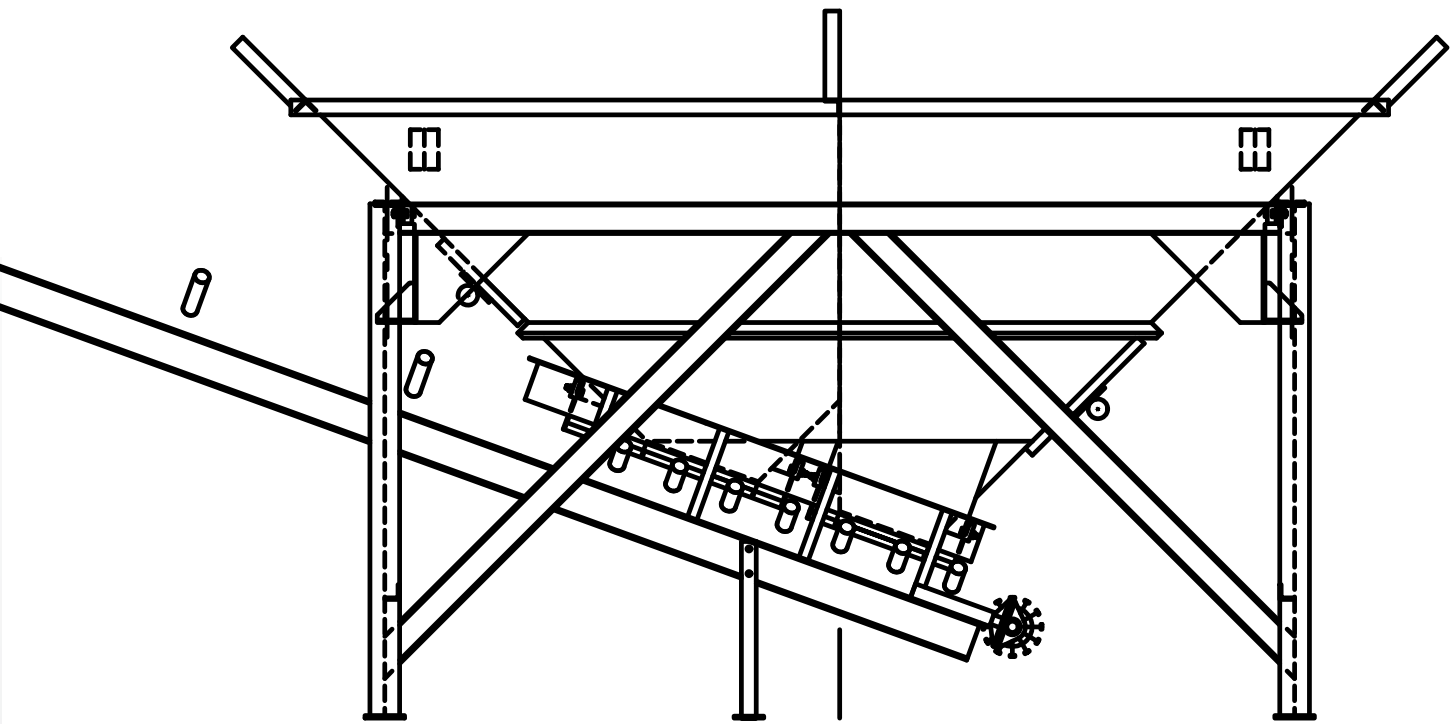
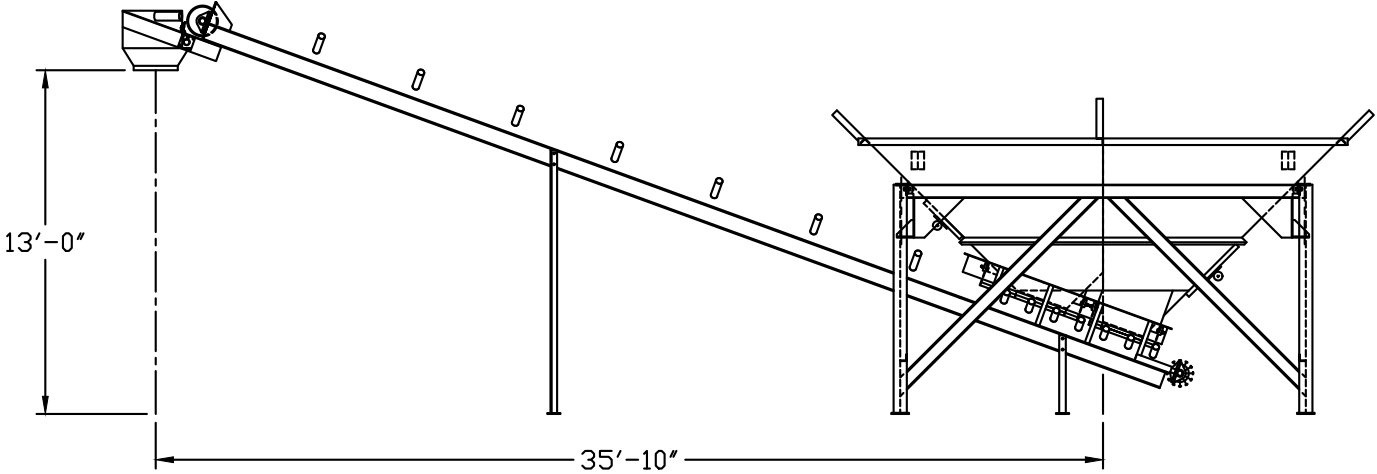

Three Compartment Aggregate Bins

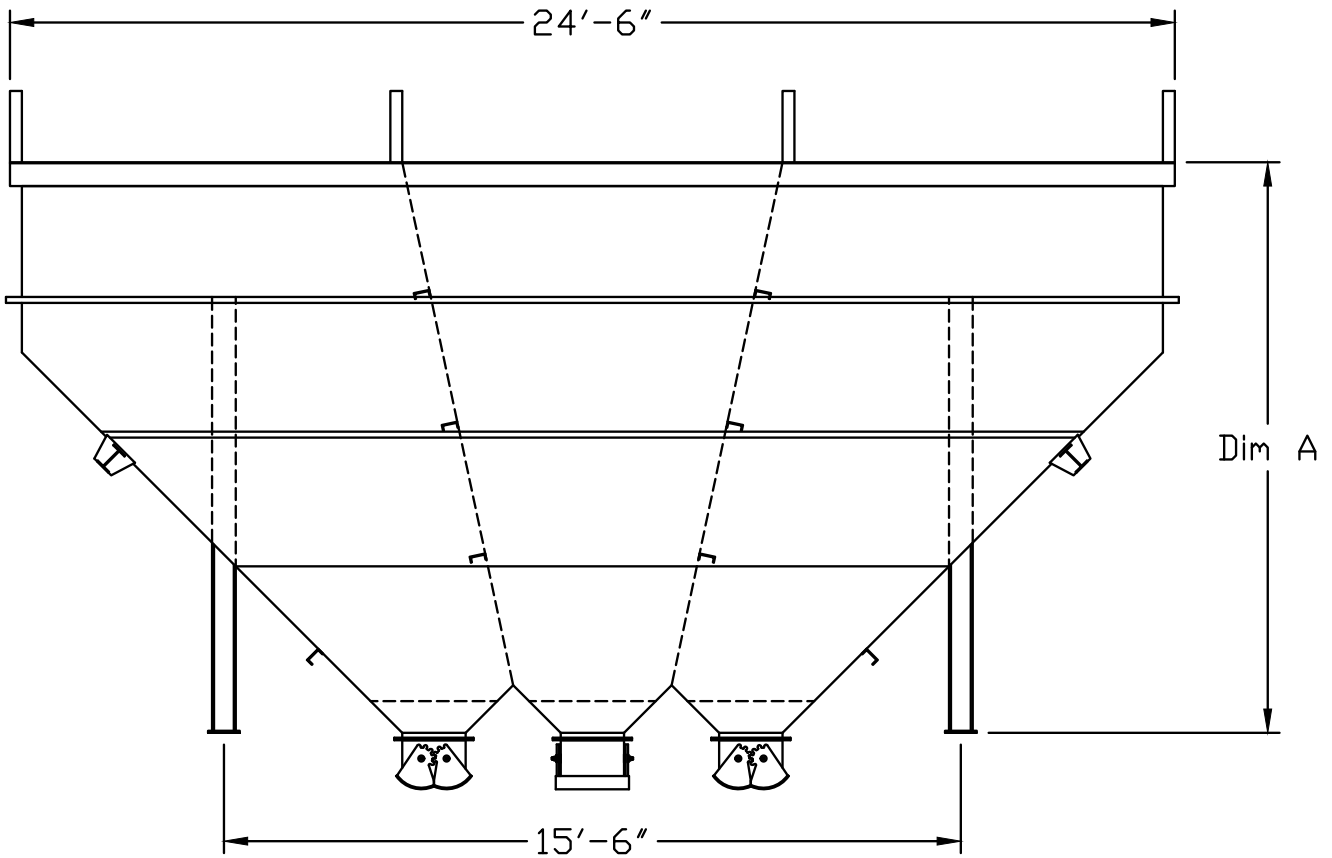

Standard Equipment

- 1/4" Thick Material on all Cones and Sloped Walls
- 3/16" Thick Material on all Straight Walls and Dividers
- Removable Heap Plates: 1'-6" High x 3/16" Thick Material
- (2) 16" x 16" Aggregate Gates with Air Cylinders
- (2) 16" x 48" Aggregate Gates with Air Cylinders
- 8" Beam Structural Stand to Provide 14'-0" Clearance Under Gates
- Optional AR Steel Liner

Capacity In Tons	Bin Height (Excluding Heap Plates)	Weight (Without Stand)	Weight (With Stand)	Dimension A
65	23'-0"	10,360#	15,900#	8'-0"
90	25'-0"	11,360#	16,900#	10'-0"
120	27'-0"	11,980#	17,500#	12'-0"
145	29'-0"	14,340#	20,200#	14'-0"
170	31'-0"	16,180#	22,100#	16'-0"
200	33'-0"	17,850#	23,800#	18'-0"

Three Compartment Aggregate Bins

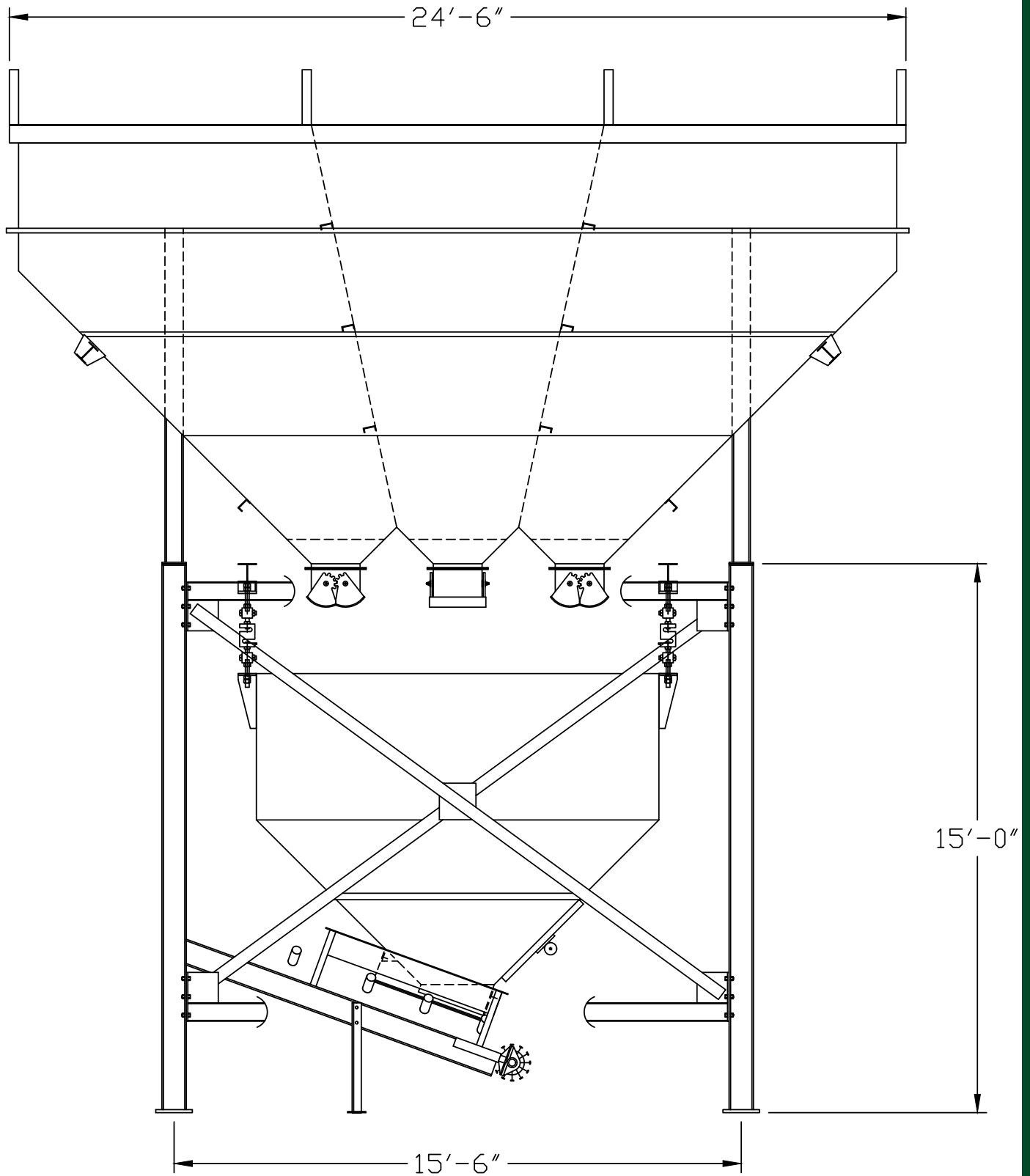

Four Compartment Aggregate Bins

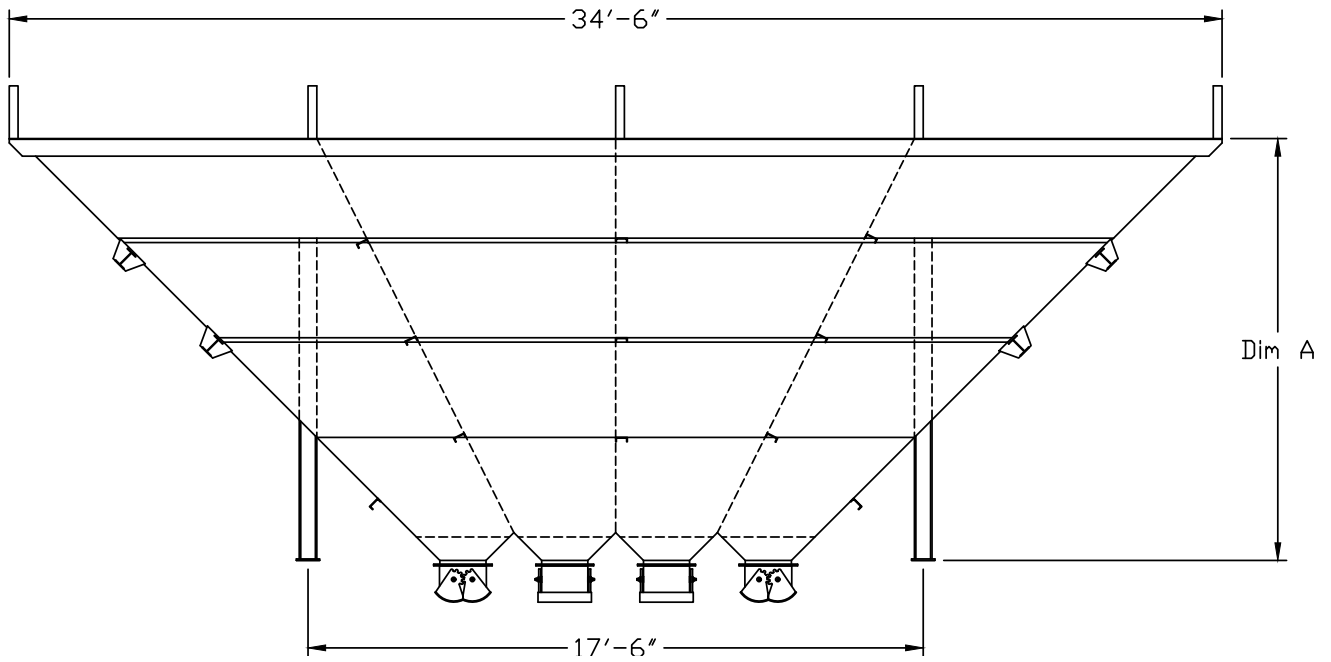

Standard Equipment

- 1/4" Thick Material on all Cones and Sloped Walls
- 3/16" Thick Material on all Straight Walls and Dividers
- Removable Heap Plates: 1'-6" High x 3/16" Thick Material
- (4) 16" x 16" Aggregate Gates with Air Cylinders
- (2) 16" x 48" Aggregate Gates with Air Cylinders
- 8" Beam Structural Stand to Provide 14'-0" Clearance Under Gates
- Optional AR Steel Liner
- Optional Window Pane Design

Capacity In Tons	Bin Height (Excluding Heap Plates)	Weight (Without Stand)	Weight (With Stand)	Dimension A
140	27'-0"	16,515#	22,700#	12'-0"
180	29'-0"	19,915#	26,100#	14'-0"
215	31'-0"	22,100#	28,300#	16'-0"

Four Compartment Aggregate Bins

